

## Description

The DCSMSxx are subminiature monolithic TVS suppressor arrays designed for the protection of sensitive IC components from the damaging effects of Electrostatic Discharge(ESD). These devices are ideally suited for use in portable electronics such as SMART phones, laptops, and other wireless devices.

The DCSMSxx are usable on I/O ports where the signal voltage is positive. These devices will also provide protection in accordance with IEC 61000-4-2 and IEC 61000-4-4 requirements. These devices are available in a SOT23-6 package configuration and is rated at 350W peak pulse power(8/20µs) per line.

## Mechanical Characteristics

- ◆ Molded JEDEC SOT23-6 Package
- ◆ Approximate Weight: 16 milligrams
- ◆ Lead -Free Pure -Tin Plating (Annealed)
- ◆ Solder Reflow Temperature:  
Pure -Tin -Sn, 100: 260-270°C
- ◆ 8mm Tape and Reel Per EIA Standard 481
- ◆ Flammability Rating UL 94V-0

## Dimensions and Pin Configuration

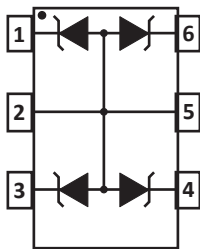

Circuit and Pin Schematic

## Features

- ◆ Compatible with IEC 61000-4-2 (ESD): Air ±15KV, Contact ±8KV
- ◆ Compatible with IEC 61000-4-4 (EFT): 40A, 5/50ns
- ◆ Compatible with IEC 61000-4-5 (Surge): 12A, 8/20µs - Level 1 (Line - Gnd) & Level 2 (Line - Line)
- ◆ 350W Peak Pulse Power per line (tp=8/20µs)
- ◆ Monolithic Design
- ◆ Protects 4 lines
- ◆ Unidirectional and Bidirectional Configurations
- ◆ ESD Protection > 25 kilovolts
- ◆ Low Clamping Voltage
- ◆ Low Leakage Current
- ◆ Available in Multiple Voltages
- ◆ RoHS Compliant
- ◆ REACH Compliant

## Applications

- ◆ SMART Phones
- ◆ Portable Electronics
- ◆ FireWire, Ethernet and USB Interfaces

## Marking Information

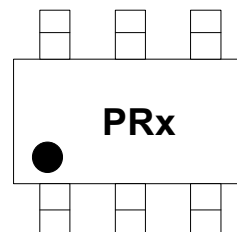

PRx = Device Marking Code  
Dot denotes Pin1

## Ordering Information

Part Number	Marking	Packaging	Reel Size
DCSMSxx	PRx	3000/Tape & Reel	7 inch

### Absolute Maximum Ratings ( $T_A=25^\circ\text{C}$ unless otherwise specified)

Parameter	Symbol	Value	Unit
Peak Pulse Power(8/20 $\mu\text{s}$ )	Ppk	350	W
Operating Temperature Range	T <sub>L</sub>	-55 to +150	°C
Storage Temperature Range	T <sub>stg</sub>	-55 to +150	°C

### Electrical Characteristics ( $T_A=25^\circ\text{C}$ unless otherwise specified)

Part Number (Note1)	Device Marking	Rated Stand-off Voltage	Minimum Breakdown Voltage	Maximum Clamping Voltage	Maximum Leakage Current	Typical Capacitance (Note 2)
		V <sub>WM</sub> (V)	@1mA V <sub>BR</sub> (V)	@I <sub>p</sub> =1A V <sub>c</sub> (V)	@V <sub>WM</sub> I <sub>d</sub> ( $\mu\text{A}$ )	@0V, 1MHz C <sub>j</sub> (pF)
DCSMS05	PRH	5.0	6.0	9.8	1	150
DCSMS12	PRI	12.0	13.3	19.0	1	80
DCSMS15	PRJ	15.0	16.7	24.0	1	50
DCSMS24	PRK	24.0	26.7	40.0	1	40

#### Notes

1. Test between pin 1 to 2 or 5, 4 to 2 or 5, 6 to 2 or 5, 3 to 2 or 5.
2. Capacitance measured between pins 1, 3, 4, 6 to 2.

**Typical Device Characteristics**

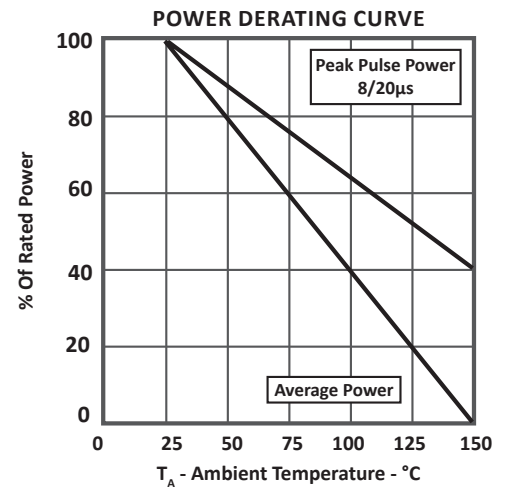
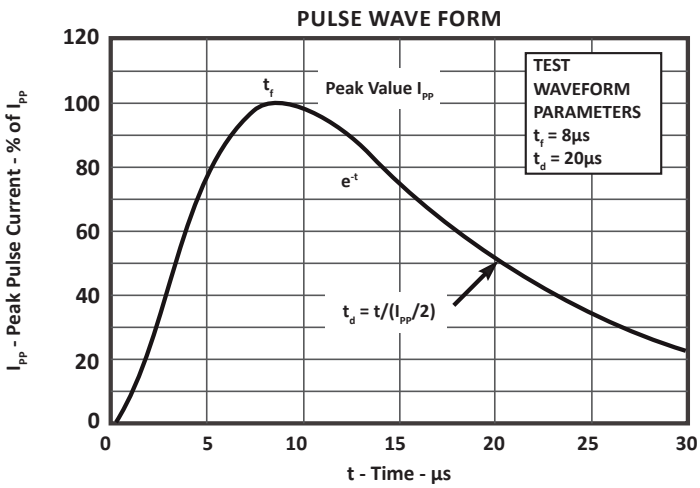
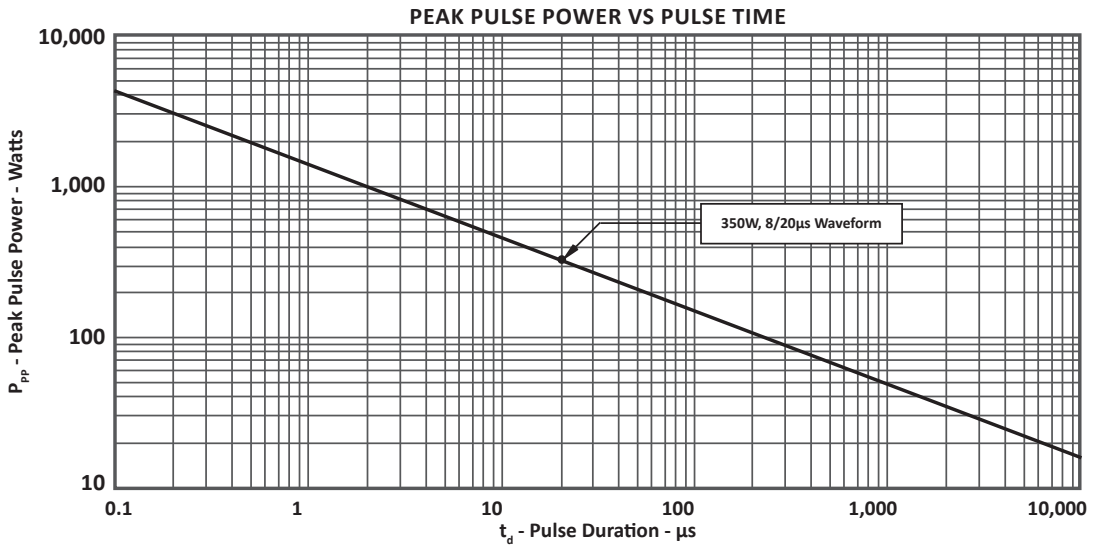

**Typical Device Characteristics**

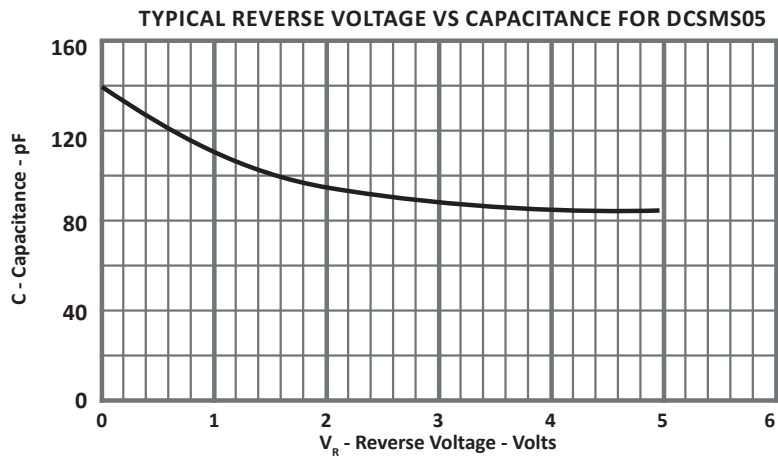
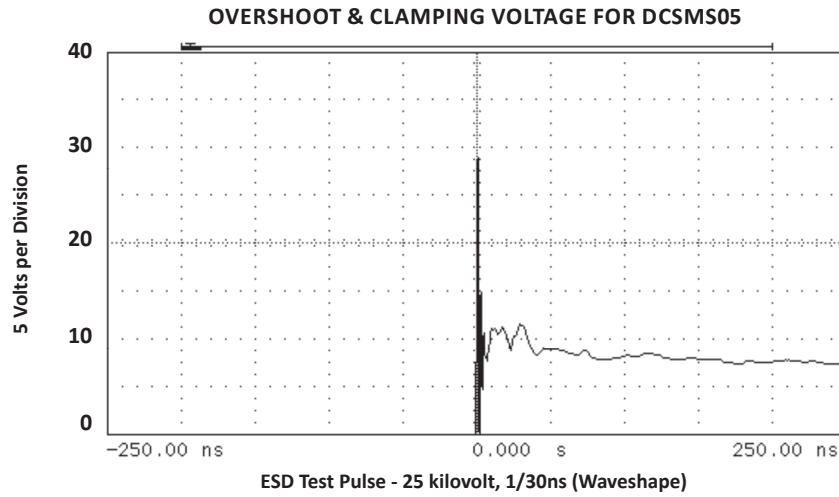

## Application Information

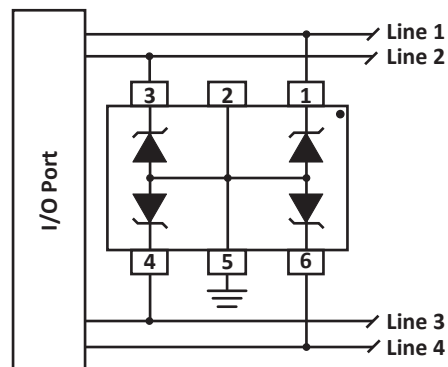

### Common-Mode I/O Port Protection

Circuit connectivity is as follows:

- Line 1 connected to pin 1.
- Line 2 connected to pin 3.
- Line 3 connected to pin 4.
- Line 4 connected to pin 6.
- Pin 5 connected to ground.
- Pin 2 not connected.

### Circuit Board Recommendations

Circuit board layout is critical for electromagnetic compatibility protection. The following guidelines are recommended: The protection device should be placed near the input terminals or connectors, the device will divert the transient current immediately before it can be coupled into the nearby traces.

The path length between the TVS device and the protected line should be minimized.

All conductive loops including power and ground loops should be minimized.

The transient current return path to ground should be kept as short as possible to reduce parasitic inductance.

Ground planes should be used whenever possible. For multilayer PCBs, use ground vias.

## SOT23-6 Package Outline Drawing

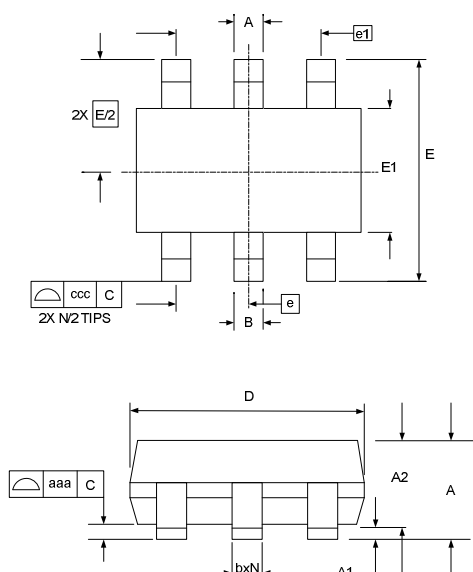

SYM	DIMENSIONS					
	MILLIMETERS			INCHES		
	MIN	NOM	MAX	MIN	NOM	MAX
A	0.90		1.45	0.035		0.057
A1	0.00		0.15	0.000		0.006
A2	0.90	1.15	1.30	0.035	0.045	0.051
b	0.25		0.50	0.010		0.020
c	0.08		0.22	0.003		0.009
D	2.80	2.90	3.10	0.110	0.114	0.122
E1	1.50	1.60	1.75	0.060	0.063	0.069
E	2.80 BSC			0.110 BSC		
e	0.95 BSC			0.037 BSC		
e1	1.90 BSC			0.075 BSC		
N	6			6		
aaa	0.10			0.004		
ccc	0.20			0.008		

## Suggested Land Pattern

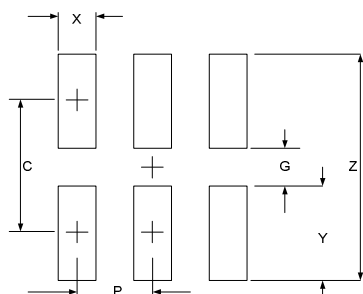

SYM	DIMENSIONS	
	MILLIMETERS	INCHES
C	2.50	0.098
G	1.40	0.055
P	0.95	0.037
X	0.60	0.024
Y	1.10	0.043
Z	3.60	0.141

## Contact Information

Changzhou D-first Electronics CO.,Ltd.

www.first-electronic.com

Email: xhf@first-electronic.cn

Phone: +86 (0519) 8817 1671